

## For Commercial Applications

Job Name \_\_\_\_\_

Contractor \_\_\_\_\_

Job Location \_\_\_\_\_

Approval \_\_\_\_\_

Engineer \_\_\_\_\_

Contractor's P.O. No. \_\_\_\_\_

Approval \_\_\_\_\_

Representative \_\_\_\_\_

# Series PWS10T

## Commercial Water Softening Systems

**Connection Size: 1" (25mm)**

**Flow Rates: Up to 25 gpm (94 lpm)**

Watts Pure Water Series PWS10T water softening systems are highly efficient, twin alternating, conventional cation exchange type water softeners. They are designed to supply continuous softened water without interruption.

Series PWS10T water softeners are suitable for commercial applications ranging from 30,000 to 120,000 grains of hardness removal per tank and flow rates up to 25 gallons per minute (94 lpm). Regeneration is meter demand initiated. All cycles of regeneration are fully automatic and do not require manual actuation.

Watts Pure Water Series PWS10T water softeners are designed for point-of-use or point-of-entry applications where the benefits of softened water are required and water demand is round the clock. These systems exchange scale-forming calcium and magnesium ions with non scale-forming sodium ions to create soft water for a variety of applications. Steam boiler make up water, water heater pretreatment, reverse osmosis pretreatment, cooling tower make up water, sterilizer make up water, washing, and process water are all common applications for the Watts Pure Water Series PWS10T water softeners.

Softened water provides a wide variety of benefits from not introducing scale into pipes, valves, water heating equipment, heat exchangers, and cooling towers to reducing mineral build up in areas that see excessive splashing such as food preparation counters and sink areas. Softened water also conserves soaps and cleaning agents by eliminating the formation of soap curd, so your cleaners can work on cleaning – not reacting with the hardness in your water.

### Features

- Durable brass bodied control valve for years of service
- Twin alternating design for continuous softened water
- WQA Certified fully automatic metered demand control valve
- Sophisticated digital electronic controls that store operating history that can be accessed by the user
- Fully adjustable regeneration cycles
- Dry contact lock out switch for remote interface is standard
- WQA Certified high capacity resin
- Highly corrosion resistant WQA or NSF Certified fiberglass tanks
- Durable polypropylene lower distribution system

## PURE WATER



**Series PWS10T**  
**Twin Alternating**

### Standards

Control Valve- WQA Certified to NSF/ANSI Std. 61 and 372  
Ion Exchange Resin- WQA Certified to NSF/ANSI Std.61  
Mineral Tank -WQA or NSF Certified to NSF/ANSI Std. 44 or 61

### Specifications

A Watts Pure Water Series PWS10T water softening system shall be installed on the building's main water line just after it enters the building. The installation point shall be after any backflow prevention or pressure regulating valves. Other installation options are to install a system just before the water heater or other types of equipment needing the protection of softened water. In installations where the dedicated cold water make up to a water heater is the installation point, a backflow preventer and a thermal expansion tank must be installed as well. The system shall be installed with a bypass valve to allow for the shut down and removal of the unit without interrupting the water supply to the building.

The water softener shall be a down flow regenerated, metered demand, sodium cycle cation exchange type system with all components necessary for proper operation.

### NOTICE

Electrical requirements are 120 volt 60 hertz. A local drain is required to accept drain water from the system. The feed water pressure must not fall below 25psi or exceed 125psi. Water temperature must not fall below 34°F or exceed 110°F (1°C to 43°C).

The system shall provide softened water measuring less than one grain per gallon of hardness as Calcium Carbonate when operated within the manufacturer's operational specifications.

Watts product specifications in U.S. customary units and metric are approximate and are provided for reference only. For precise measurements, please contact Watts Technical Service. Watts reserves the right to change or modify product design, construction, specifications, or materials without prior notice and without incurring any obligation to make such changes and modifications on Watts products previously or subsequently sold.



## Feed Water Guidelines

pH ..... 6 to 10  
 Hardness (maximum) ..... Depends on customers acceptable hardness leakage level.  
 Water Pressure. .... 25psi to 125psi (171 kPa to 8.5 bar)  
 Temperature. .... 34 - 110°F (1 - 43°C)  
 Free Chlorine (maximum) ..... 1mg/L  
 Iron (maximum). .... 1mg/L  
 Oil and H2S ..... None Allowed  
 Turbidity ..... Less than 5.0 NTU  
 For all other guideline information please contact your Watts representative.

**⚠ WARNING**

Do not use with water that is microbiologically unsafe or of unknown quality without adequate disinfection before or after the system.

## Dimensions - Weights

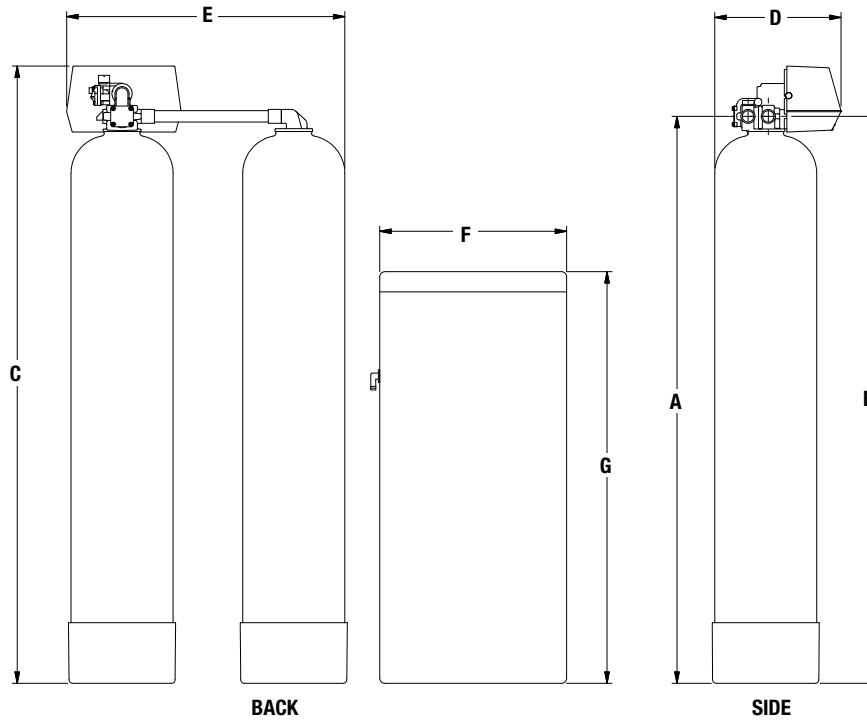

MODEL NO.	DIMENSIONS														WEIGHTS	
	A		B		C		D		E		F		G		lbs.	kgs.
	in.	mm	in.	mm	in.	mm	in.	mm	in.	mm	in.	mm	in.	mm		
PWS10T161A21	50	1270	50	1270	55	1397	12	305	27 <sup>3</sup> / <sub>8</sub>	695	18	457	40	1016	230	105
PWS10T161B21	56 <sup>1</sup> / <sub>8</sub>	1425	56 <sup>1</sup> / <sub>8</sub>	1425	61 <sup>1</sup> / <sub>8</sub>	1552	12 <sup>1</sup> / <sub>2</sub>	318	27 <sup>7</sup> / <sub>8</sub>	708	18	457	40	1016	290	132
PWS10T161C21	54 <sup>1</sup> / <sub>2</sub>	1384	54 <sup>1</sup> / <sub>2</sub>	1384	59 <sup>1</sup> / <sub>2</sub>	1511	13 <sup>1</sup> / <sub>2</sub>	343	29 <sup>1</sup> / <sub>2</sub>	749	18	457	40	1016	350	159
PWS10T161D21	67 <sup>3</sup> / <sub>8</sub>	1711	67 <sup>3</sup> / <sub>8</sub>	1711	72 <sup>1</sup> / <sub>4</sub>	1835	14 <sup>5</sup> / <sub>8</sub>	371	31 <sup>1</sup> / <sub>2</sub>	800	18	457	40	1016	500	227
PWS10T161E21	66 <sup>5</sup> / <sub>8</sub>	1692	66 <sup>5</sup> / <sub>8</sub>	1692	71 <sup>5</sup> / <sub>8</sub>	1819	16 <sup>1</sup> / <sub>8</sub>	409	33 <sup>1</sup> / <sub>8</sub>	841	18	457	40	1016	650	295

MODEL NO.	MINERAL TANK			BRINE TANK		SOFTENING CAPACITY		LBS. SALT PER REGENERATION		FLOW RATE & PRESSURE		
	TANK SIZE	RESIN FT <sup>3</sup>	GRAVEL #20	TANK SIZE	SALT FILL	MAX	MIN	MAX	MIN	SERV GPM	DROP PSI	BKW GPM
PWS10T161A21	9" x 48"	1.0	10 lbs.	18" x 40"	400	30 K	20 K	15	6	9/15	15/25	2.0
PWS10T161B21	10" x 54"	1.5	10 lbs.	18" x 40"	400	45 K	30 K	22.5	9	10/15	15/25	2.4
PWS10T161C21	12" x 52"	2.0	30 lbs.	18" x 40"	400	60 K	40 K	30	12	15/20	15/25	3.5
PWS10T161D21	14" x 65"	3.0	60 lbs.	18" x 40"	400	90 K	60 K	45	18	18/23	15/25	5.0
PWS10T161E21	16" x 65"	4.0	80 lbs.	18" x 40"	400	120 K	80 K	60	24	19/25	15/25	7.0

MODEL NO.	DESCRIPTION	PIPE SIZE	SPACE REQUIRED		WEIGHT	
			D X W X H	LBS	KGS	
PWS10T161A21	1 Cubic Foot Twin Alt. Water Softener with Flow Meter	1"	18" x 51" x 70"		230	105
PWS10T161B21	1.5 Cubic Foot Twin Alt. Water Softener with Flow Meter	1"	18" x 51" x 76"		290	132
PWS10T161C21	2 Cubic Foot Twin Alt. Water Softener with Flow Meter	1"	18" x 53" x 74"		350	159
PWS10T161D21	3 Cubic Foot Twin Alt. Water Softener with Flow Meter	1"	18" x 58" x 87"		500	227
PWS10T161E21	4 Cubic Foot Twin Alt. Water Softener with Flow Meter	1"	18" x 62" x 87"		650	295

**Notes:** Capacities are based on resin manufacturer's data and are dependent upon influent water TDS, temperature, bed depth, and flow rates. Feed water must be free of oil and color. Pipe size, tank size, and space requirements are in inches. Capacities and flow rates expressed above are per tank. Flow rates listed at 25psi drops are for intermittent peak flow rates and are not to be used as continuous flows.

### NOTICE

The information contained herein is not intended to replace the full product installation and safety information available or the experience of a trained product installer. You are required to thoroughly read all installation instructions and product safety information before beginning the installation of this product.



A Watts Water Technologies Company

USA: Tel: (800) 224-1299 • Fax: (978) 794-1848 • [Watts.com/PureWater](http://Watts.com/PureWater)

Canada: Tel: (905) 332-4090 • Fax: (905) 332-7068 • [Watts.ca/PureWater](http://Watts.ca/PureWater)

Latin America: Tel: (52) 81-1001-8600 • Fax: (52) 81-8000-7091 • [Watts.com/PureWater](http://Watts.com/PureWater)