

ITEM NO.	PART NUMBER	QTY.
1	BASE	1
2	BASE BOTTOM LOCK NUT	1
3	GEAR BOX TOP LOCK NUT	1
4	GEAR BOX WITH VALVE	1
5	GEAR BOX BOTTOM LOCK NUT	1
6	SET SCREW	2
7	SPRAY WITH HOSE	1

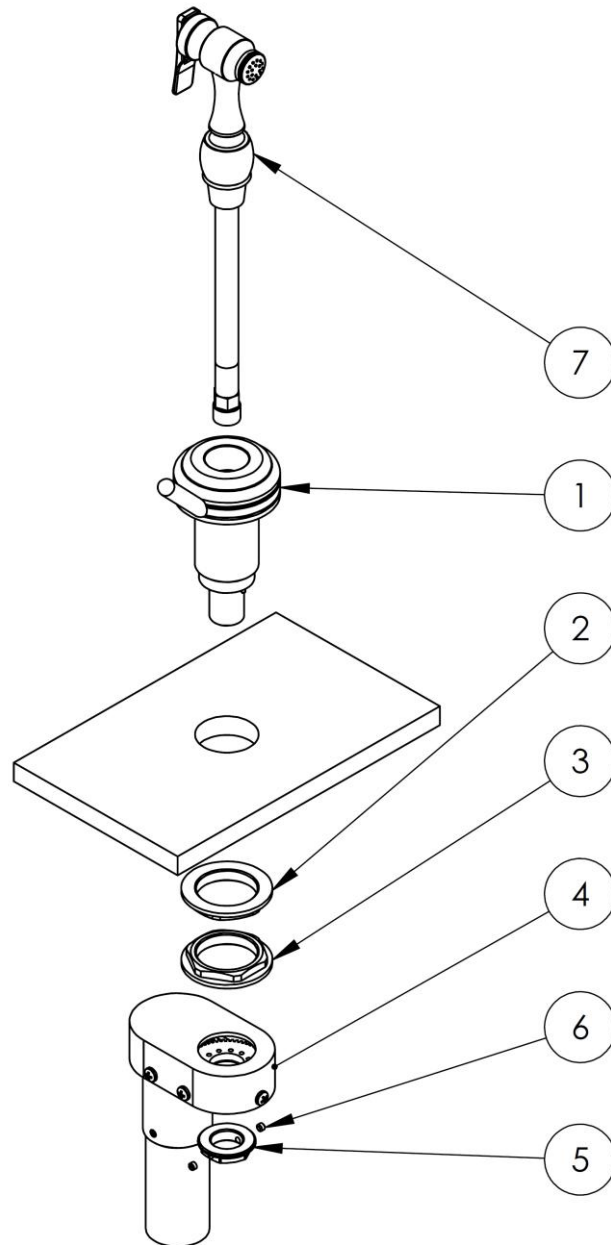

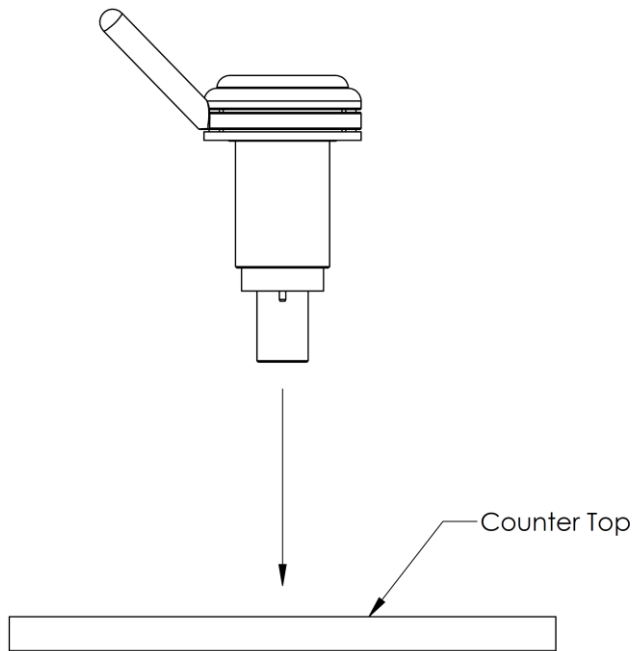

1. Place base through hole in counter top.

NOTE: 1 3/8" diameter hole needed for deck

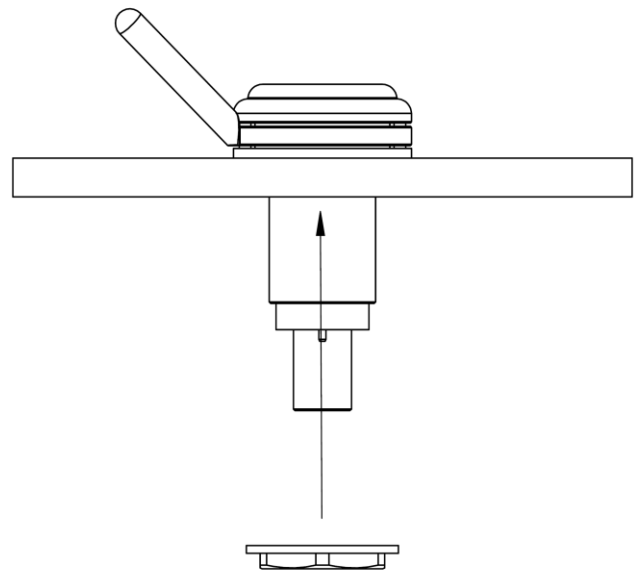

2. Tighten base onto counter making sure base is aligned so lever can turn equally to the right and to the left. Turn lever to leftmost position.

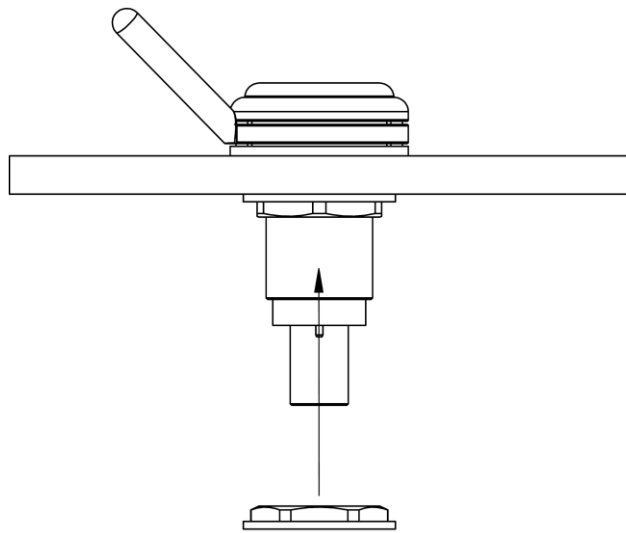

3. Screw gear box top lock nut onto base. Do not tighten.

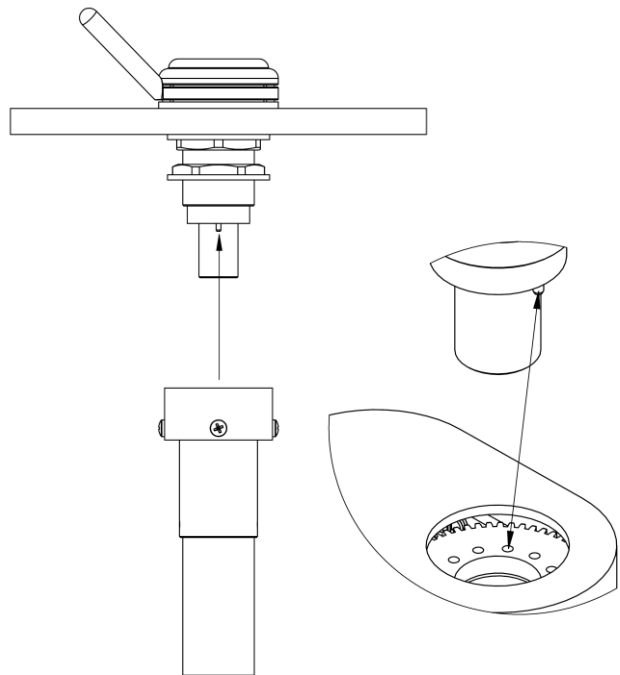

4. Raise gear box with valve up to base. The valve may be aligned in any direction. Gear box may need to be turned slightly in order for pins to properly mate with gear.

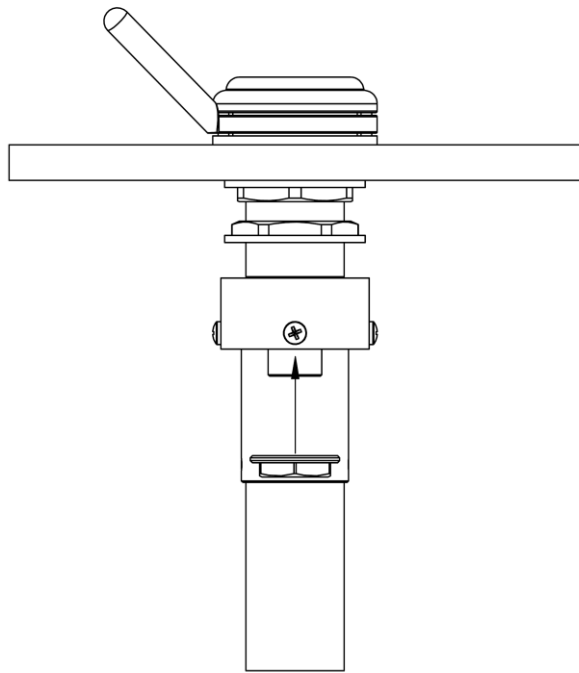

5. Screw gear box bottom lock nut onto base until it contacts the bottom of the gear box. Do not tighten.

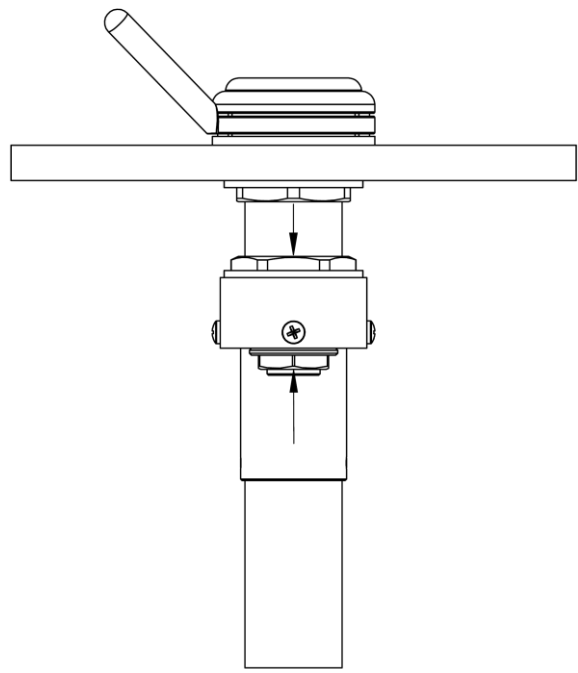

6. Lower gear box top lock nut until it touches the top of the gear box. Tighten top and bottom lock nuts.

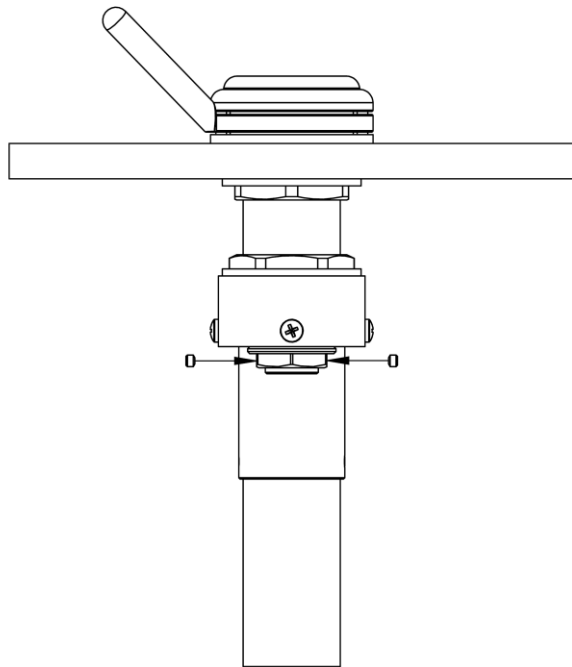

7. Tighten gear box bottom lock nut set screws. One or both set screws may be tightened.

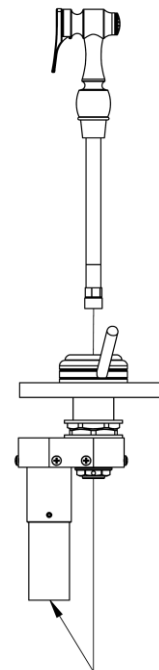

8. Put hose through hole in base and screw into correct port on valve.

9. Attach cold and hot supply hoses to valve.

10. Verify handle and valve are aligned properly by pushing the button on the spray and turning the handle from all the way left to all the way right. When in the leftmost position the water flow should be off. As the handle is turned to the right the water should progress from off – low cold – high cold – high mixed – high hot – low hot. If turning the handle from the leftmost position to the rightmost position does not produce the full range of flow please see the troubleshooting guide.

Troubleshooting Guide

If the valve cannot be opened or closed fully or if the spray is leaking through the head:

1. Loosen gear box bottom lock nut and lower gear box until the gear disengages from the pin.
2. Turn the handle all the way to the right.
3. Raise the gear box so the pins mates with the gear. The gear box should not be tightened on at this point.
4. Holding the gear box in place, turn the handle to the left until it stops.
5. Lower the gear box to disengage from pins.
6. Turn the handle all the way to the left. Repeat steps 4 – 7 of the installation instructions.