



7 SERIES GAS RANGES

Viking 7 Series – VGR

COMMERCIAL-TYPE SURFACE POWER

- **EXCLUSIVE** Viking Elevation™ Burners with brass flame ports boast 23,000 BTUs across the front of all width configurations, with multiple 15,000 BTUs and one 8,000 BTU burner across the rear
- Three burner sizes efficiently deliver heat to any size cookware
- **EXCLUSIVE** VariSimmer™ Setting on ALL burners provides gentle, even simmering at precisely low cooking temperatures
- **EXCLUSIVE** SureSpark™ Ignition System, ensures automatic ignition/re-ignition, should the burners extinguish at any time while cooking

REVERSIBLE GRIDDLE/GRILL

- Thermostatically controlled non-stick griddle heats evenly to provide consistent cooking across the entire surface and can be easily removed for cleaning
- Reversible Griddle/Grill features the **PATENT PENDING** StayCool™ Trough Handle and grease containment system that strategically directs excess grease into a removable capture trough for quick and easy cleanup
- Optional ViChrome™ Griddle accessory interchanges with the non-stick griddle providing versatility for griddling and easy cleanup



INNOVATIVE FEATURES

- **EXCLUSIVE** GentleClose™ Door allows the door to slowly close, ensuring delicate baked goods are not disturbed
- **EXCLUSIVE** TruGlide™ Full Extension Racks for safe and easy removal of heavy bakeware
- **EXCLUSIVE** BlackChrome™ Knobs with CoolLit™ LED Backlighting

EASY OPERATION AND CLEANUP

- **EXCLUSIVE** seamless, heavy gauge porcelain burner pan with elevated flame ports prevent spillovers from baking on, making cleanup easy
- Continuous grate design allows easy movement of pots and pans from burner to burner
- Easy to clean porcelainized oven cavity
- Grates, burner caps, knobs, griddle and accessories can be easily removed and taken to the sink for cleaning

GAS OVEN FUNCTIONS

- Extra-large capacity oven has enough space to accommodate various size bakeware for multi-rack cooking
 - 36"W. models can accommodate a full size commercial sheet pan
- Six high-performance cooking modes: natural airflow bake, convection bake, infrared broil, convection infrared broil, convection dehydrate and convection defrost
- **EXCLUSIVE** combination of single 30,000 BTU U-shaped burner and infrared broiler with SureSpark™ Ignition System (15,000 BTU burner in left oven of 48"W. models)
- Gourmet Glo™ Infrared Broiler provides intense searing heat to lock in savory juices
- **EXCLUSIVE** Proflow™ Convection Baffle circulates heat in oven cavity to maximize even cooking (right oven only in 48"W. models)
- **NEW** larger window openings

MODEL NUMBERS

- VGR73626B – 36."W. Gas Range; 6 burners
- VGR73624G – 36."W. Gas Range; 4 burners with griddle
- VGR74828B – 48."W. Gas Range; 8 burners
- VGR74826G – 48."W. Gas Range; 6 burners with griddle

ACCESSORIES

- BG107362SS – 10"H. backguard for 36" range
- BG107482SS – 10"H. backguard for 48" range
- HS24736SS – 24"H. high shelf for 36" range
- HS24748SS – 24"H. high shelf for 48" range
- P36CRTSS – countertop rear trim for 36" range
- P48CRTSS – countertop rear trim for 48" range
- CRG7VGR – ViChrome Griddle (for use with griddle model)
- LPKVGR – LP/Propane conversion kit for 7 Series
- GCKVGR – gas connector kit
- CBGVGR – bamboo cover for griddle
- WOKVGR7 – wok ring accessory

COLOR FINISHES

- Stainless Steel (SS), Black (BK), and White (WH)
- Available in 14 exclusive color finishes Alluvial Blue (AB), Arctic Gray (AG), Black Forest Green (BF), Bywater Blue (BW), Cast Black (CS), Cypress Green (CY), Damascus Gray (DG), Frost White, (FW) Kalamata Red (KA), Pacific Gray (PG), Reduction Red (RE), Slate Blue (SB), San Marzano Red (SM), Vanilla Cream (VC)



WARRANTY

- 2-year full – complete product
- 90-day full – cosmetic parts such as glass, painted items and decorative items
- 5-year limited – gas burners



7 SERIES GAS RANGES

Viking 7 Series – VGR

GAS 36" AND 48" W. RANGES		
DESCRIPTION	VGR73626B/VGR73624G	VGR74828B/VGR74826G
Overall Width	35-7/8" (91.1 cm)	47-7/8" (121.6 cm)
Overall Height	To top of side trim – 35-15/16" (91.3 cm) min. 37-9/16" (95.4 cm) max. Legs adjust – 1-5/8" (4.1 cm)	
Overall Depth from Rear*	To end of side panel – 25-1/4" (64.1 cm) To front of door – 26-15/16" (68.4 cm) To end of door handle – 30" (76.2 cm) *Add 3/4" (1.9 cm) to overall depth for models installed against a combustible wall.	
Additions to Base Height	To top of island trim – add 1" (2.5 cm) To top of backguard – add 10" (25.4 cm) To top of high shelf – add 24-1/8" (61.3 cm)	
Gas Manifold Pressure	Natural 5.0" W.C.P./ Liquid Propane LP 10.0" W.C.P.	
Surface Burner Rating Natural Gas/LP	Front: (3) 23,000 BTU (6.7 kW) / 20,000 BTU (5.8 kW) Rear: (2) 15,000 BTU (4.4 kW) / 13,500 BTU (4.0 kW) (1) 8,000 BTU (2.3 kW) / 8,000 BTU (2.3 kW)	Front: (4) 23,000 BTU (6.7 kW) / 20,000 BTU (5.8 kW) Rear: (3) 15,000 BTU (4.4 kW) / 13,500 BTU (4.0 kW) (1) 8,000 BTU (2.3 kW) / 8,000 BTU (2.3 kW)
Griddle Burner Rating	15,000 BTU Nat./13,500 BTU LP (4.4 kW Nat/4.0 kW LP)	
Gas Requirements	Shipped Natural or LP/Propane, accepts standard residential 1/2" (1.3 cm) ID gas service line. Unit is field convertible with proper conversion kit	Shipped Natural or LP/Propane, accepts standard residential 3/4" (1.9 cm) ID gas service line. Unit is field convertible with proper conversion kit
Electrical Requirements	120VAC/60 Hz; 4 ft. (121.9 cm), 3-wire cord with grounded 3-prong plug attached to unit	
Maximum Amp Usage	1.5 amps	2.0 amps
Oven Interior Width	29" (73.7 cm)	Right oven – 23" (58.4 cm) Left oven – 12-1/8" (30.8 cm)
Oven Interior Height	16-1/8" (40.9 cm)	
Oven Interior Depth Overall Measured to Aham Standard**	18-3/4" (47.6 cm) 17" (43.2 cm)	
Oven Volume Overall Measured to Aham Standard**	5.1 cu. ft. 5.1 cu. ft.	Right - 4.0 cu. ft. / Left - 2.1 cu. ft. Right - 3.7 cu. ft. / Left - 2.0 cu. ft.
Approximate Shipping Weight	525 lbs. (236.6 kg)	692 lbs. (314 kg)

Please do not prepare installation from brochure data only. See installation instructions for important clearance/installation information.
**The AHAM Standard for measuring oven capacity subtracts the door plug and convection baffle dimension from the total oven volume.

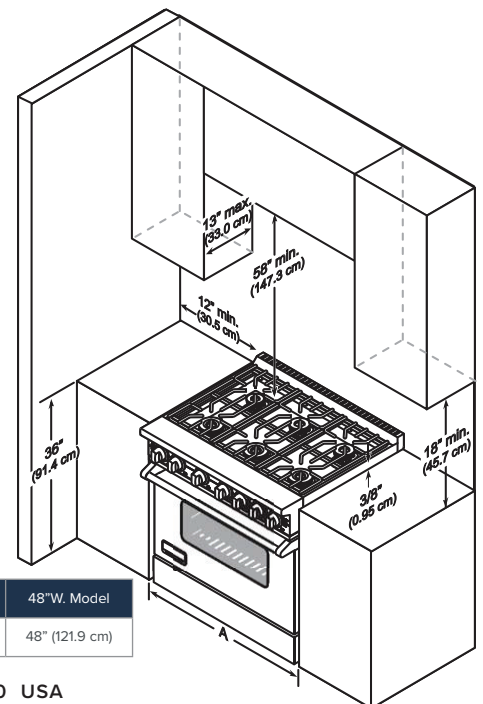
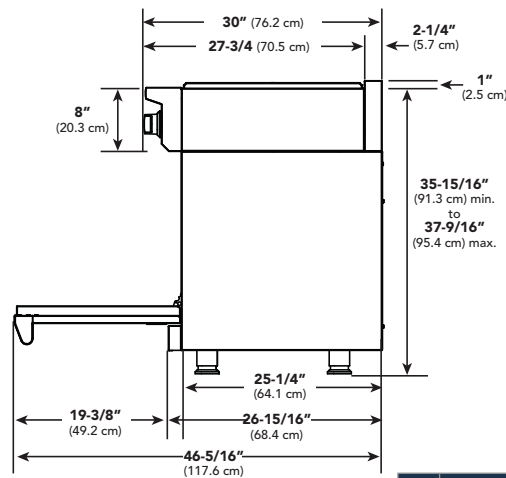
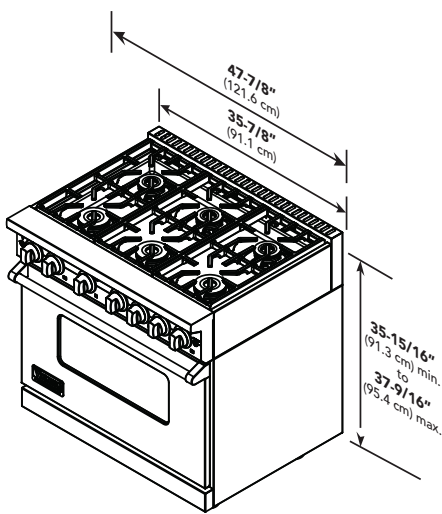

	36" W. Model	48" W. Model
A	36" (91.4 cm)	48" (121.9 cm)



VIKING RANGE, LLC 111 FRONT STREET GREENWOOD, MISSISSIPPI 38930 USA

For detailed product information, model numbers, or to request a quote call 1-888-845-4641 or visit vikingrange.com
© 2020 Viking Range, LLC All rights reserved. Specifications subject to change without notice.