



# 36" French Door Refrigerator



Specifications		
General Features	<b>Model Number</b>	<b>VERF36CDSS</b>
	Size	36"
	Capacity	22.5 Cu. Ft.
	Style	French Door – 2 Freezer Drawers
	Handle Style	Professional - Stainless Steel
	Finish	Stainless Steel – Flat
	Defrost Type	Automatic
	Electrical Requirements	115Volt 60Hz.
	Energy Start Certified	Yes
	UL Certification	Yes
	Interior Lighting	Top and Side Lighting
	Auto Ice Maker	2.8 lbs. per 24 hour cycle
	Crisper Drawers	2, Humidity Controlled
	Temperature Range	34° F - 45° F
	Gallon Storage Drawer	Yes
	Adjustable Shelves	Yes
Number of Shelves	4 Internal, 6 in the Door	
Freezer Type	2 Pullout Drawers	
Freezer Temp Range	-14° F - 0° F	
Dimensions	<b>Dimensions</b>	
	Width (in)	35 5/8
	Depth (in)	29
	Height (in)	69 7/8
	Refrigerator Volume	15.87 Cu. Ft.
	Freezer Volume	6.62 Cu. Ft.
	Net Weight (lbs.)	282 lbs.
	Shipping Weight (lbs.)	297 lbs.

## Features

- Sleek design, with dual freezer drawers to easily organize and access frozen foods.
- Electronic temperature controls, and energy efficient interior LED lights on both top and sides.
- 22.5 Cu. Ft. Counter-depth gives a built-in look while maximizing capacity
- Keep produce fresh, longer with double crisper drawers with humidity controls.
- Spill-proof glass shelves feature a raised outer rim.
- Convenient full-width pantry drawer stores large party trays, or pizza boxes.
- Internal Auto Ice Maker

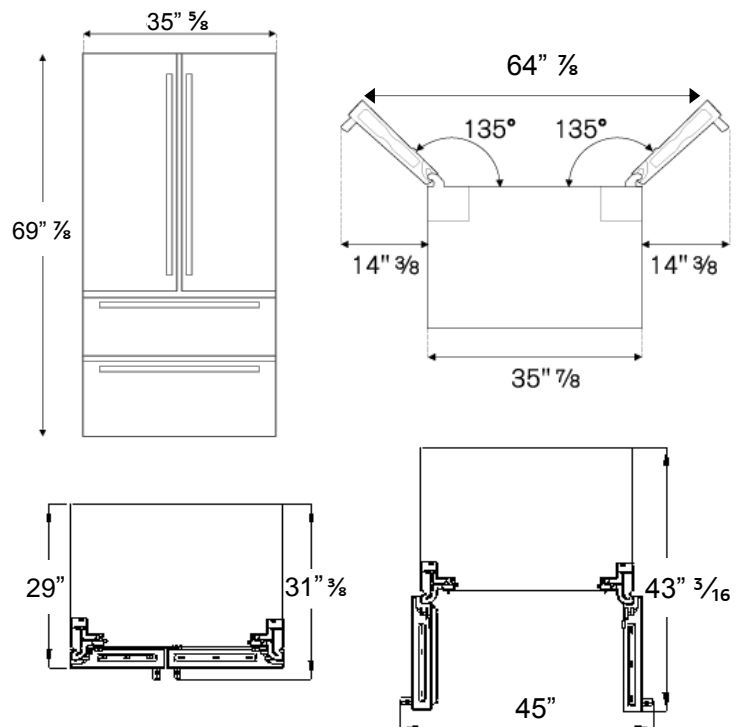

Energy Verified  
Rendement  
Énergétique Vérifié

