

## 200 PSI Flanged End Butterfly Valves

Polyamide Coated Cast Iron Body • Extended Neck • Cold form Stem Drive  
 • Elastomer Encapsulated Disc • Flanged Ends • Maximum Temperature 200°F with EPDM Only • ASME B16.10 Face-to-Face Dimensions

Patent pending

Sizes 2" through 12"

DESIGNED TO MEET MSS SP-67 STANDARD



**FC-27\*5-0**

\*Optional disc  
 EPDM (6)  
 or BUNA (7)

### MATERIAL LIST

PART	SPECIFICATION
1. Upper Stem	Stainless Steel, ASTM A582 Type 416
2. Upper Bushing	PTFE over Porous Bronze, Steel Backed
3. O-Ring	EPDM or BUNA-N
4. Body	Cast Iron ASTM A126 Class B with Polyamide Coating
5. Disc	Ductile Iron ASTM A395 with EPDM or BUNA-N Encapsulation
6. Lower Bushing	PTFE over Porous Bronze, Steel Backed
7. Lower Stem	Stainless Steel, ASTM A582 Type 416
8. Dust Plug	PVC
9. Nameplate	Aluminum

Class 125 flange ends

Polyamide coating has NSF certification

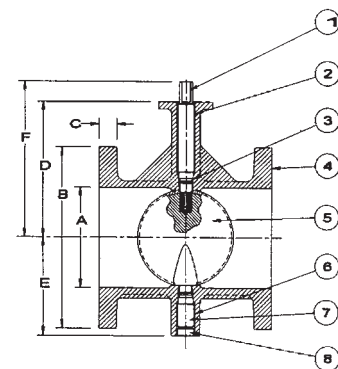

### DIMENSIONS — WEIGHTS

Size		A	B	C	D	E	F	G	J
In.	mm.								
2	50	2.11	6.0	0.62	5.69	3.16	6.94	7.00	0.437
2 1/2	65	2.59	7.0	0.69	5.78	3.25	7.03	7.50	0.437
3	80	3.07	7.5	0.75	5.99	3.54	7.24	8.00	0.437
4	100	4.03	9.0	0.94	6.99	4.35	8.24	9.00	0.437
5	125	5.05	10.0	0.94	7.47	4.85	8.72	10.00	0.437
6	150	6.07	11.0	1.00	8.28	5.94	9.53	10.50	0.437
8	200	7.98	13.5	1.12	9.25	6.87	10.50	11.50	0.437
10	250	10.02	16.0	1.19	11.03	9.18	12.28	13.00	0.562
12	300	12.00	19.0	1.25	12.01	10.16	13.26	14.00	0.562

Size		Weight								
In.	mm.	K	L	M	N	P	Q	R	Lbs.	Kg.
2	50	3.25	3.25	0.50	0.37	0.75	4.75	4	16.5	7.5
2 1/2	65	3.25	3.25	0.50	0.37	0.75	5.50	4	24	10.9
3	80	3.25	3.25	0.50	0.37	0.75	6.00	4	28	12.7
4	100	3.25	3.25	0.66	0.50	0.75	7.50	8	44	20.0
5	125	3.25	3.25	0.66	0.50	0.88	8.50	8	53	24.1
6	150	3.25	3.25	0.78	0.56	0.88	9.50	8	65	30.0
8	200	3.25	3.25	0.78	0.56	0.88	11.75	8	94	42.7
10	250	5.00	4.75	1.06	0.75	1.00	14.25	12	155	70.4
12	300	5.00	4.75	1.06	0.75	1.00	17.00	12	214	97.6

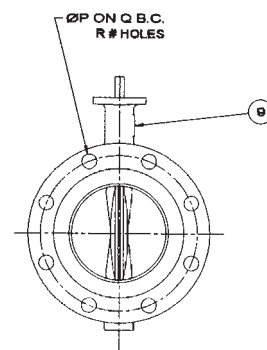
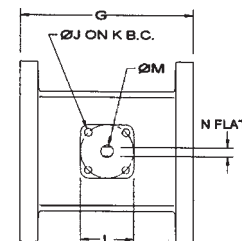

NOT RECOMMENDED FOR STEAM SERVICE

**WARNING:** This product can expose you to chemicals including lead, which is known to the State of California to cause cancer and birth defects or other reproductive harm. For more information go to [www.P65Warnings.ca.gov](http://www.P65Warnings.ca.gov).

Visit our website for the most current information.