

FLOOR DRAINS

HEAVY DUTY DRAINS - SEDIMENT BUCKET TRACTOR GRATE

FUNCTION: Used in heavy trucking areas where debris is anticipated and must be intercepted. The suspended sediment bucket when set under the grate guarantees efficient interception of debris.

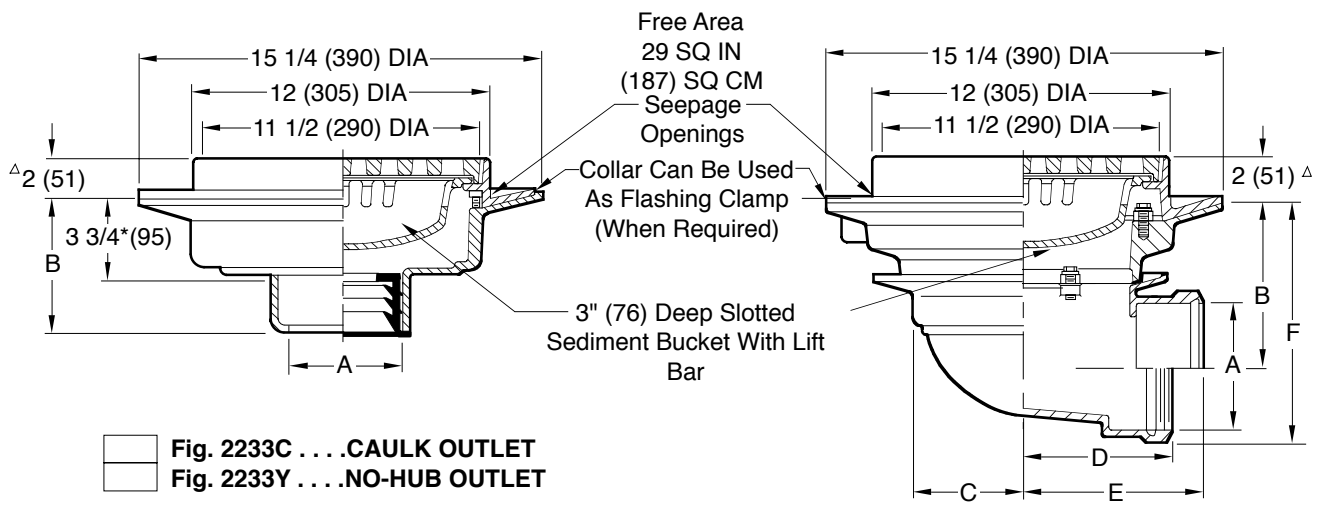

Fig. 2233C . . . CAULK OUTLET
 Fig. 2233Y . . . NO-HUB OUTLET

A Size	B	
	Caulk, NO-HUB, & Speedi-Set	Threaded
02(50), 03(80), 04(100), 05(125) or 06(150)	5 (125)	3 3/4 (95)

Fig. 2238C . . . CAULK OUTLET
 Fig. 2238T . . . THREADED OUTLET

A SIZE	02 (50)	03 (80)	04 (100)	05 (125)	06 (150)
B	6 7/8 (175)	6 3/8 (162)	5 7/8 (149)	5 (125)	4 1/2 (115)
C	4 3/4 (120)	4 3/4 (120)	4 3/4 (120)	6 1/4 (160)	6 1/4 (160)
D	6 (150)	6 (150)	6 (150)	6 5/8 (168)	6 7/8 (175)
E	7 1/4 (185)	7 1/2 (190)	7 3/4 (195)	7 3/4 (195)	7 3/4 (195)
F	8 5/8 (219)	8 3/4 (220)	8 3/4 (220)	8 1/2 (215)	8 1/2 (215)

REGULARLY FURNISHED:
 Duco Cast Iron Body and Flashing Collar with Cast Iron Tractor Grate and Slotted Sediment Bucket.

*This Dimension to Internal Stop of Speedi-Set Gasket.
 Δ Add 1/8"(3) when bronze top is specified

- VARIATIONS:**
- L Speedi-Set Service Weight 02(50), 03(80) & 04"(100) sizes only (Fig. 2233 only)
 - LXH Speedi-Set Extra Heavy 02(50), 03(80) & 04"(100) sizes only (Fig. 2233 only)
 - NO-HUB Adaptor (Specify Fig. 2646Y) (Fig. 2238 only)
 - Square Top -S
 - Trap Primer Connection -P050 1/2"(13) & -P075 3/4"(19) (Fig. 2233 only)
 - Vandal Proof Grate -U
 - T Threaded Outlet
 - Quad Close Trap Seal (Specify Fig. 2692) (Fig. 2233 Only)

- OPTIONAL MATERIALS:**
- Ductile Iron Grate -M
 - Galvanized Cast Iron -G
 - Nickel Bronze Top -NB
 - Polished Bronze Top -PB

NOTE: 02(50),03(80), & 04"(100) sizes require a transition collar (as shown in above illustration) which fits between the body & collar. 05(125) & 06"(150) sizes do not require transition collar.

NOTE: Dimensions shown in parentheses are in millimeters.

DRAWING NUMBER S2233
 SIZE A
 SCALE: NONE
 DATE: 5-17-85
 APPROVED BY: TD
 CHECKED BY: TD
 DRAWN BY: PJ
2233, 2238
 DIMENSIONS ARE SUBJECT TO MANUFACTURERS TOLERANCE AND CHANGE WITHOUT NOTICE

REV.	DATE	DESCRIPTION	BY	CKD. BY	WEIGHT POUNDS	VOLUME CUBIC FEET	FIGURE NUMBER
							2233, 2238