

ADJUSTABLE FIXTURE SUPPORTS

FOR SIPHON JET WATER CLOSETS - SHALLOW ROUGH-IN TYPE

VERTICAL FITTINGS WITH SIDE INLET

SINGLE

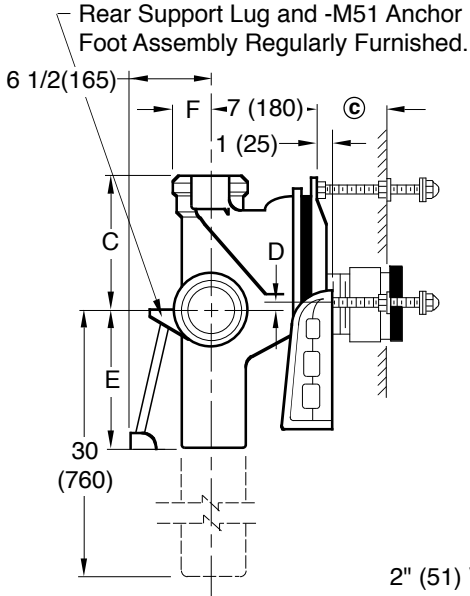

Fig. 0240L Side View

DOUBLE

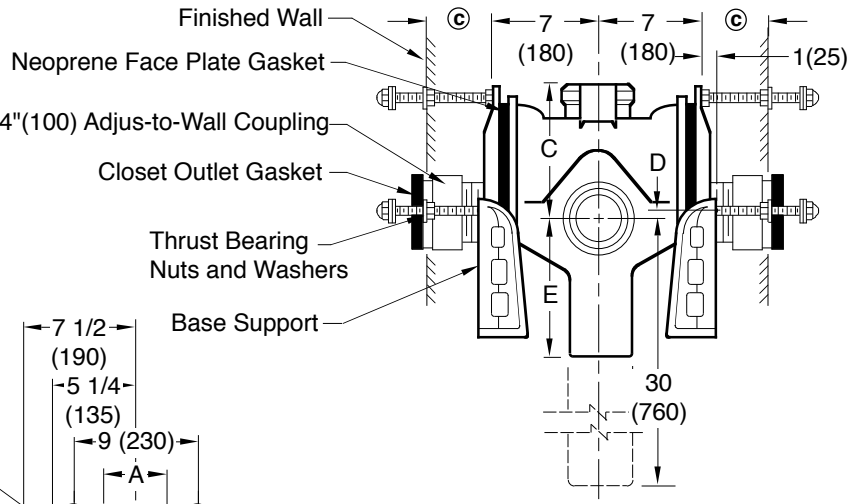
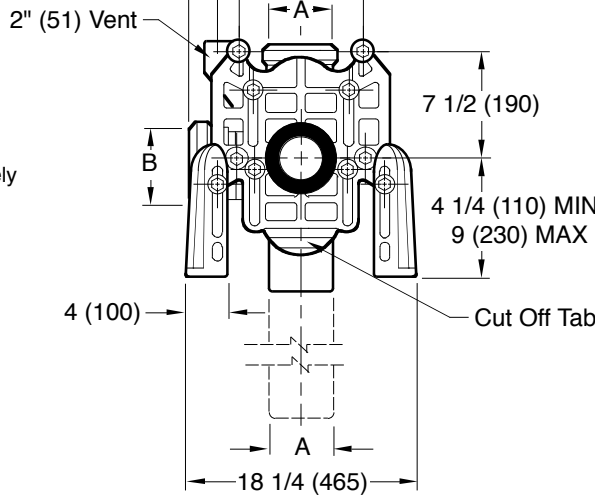

Fig. 0240D Side View



Front View

NOTE: Base support must be securely anchored to floor (with four 1/2" (13) bolts provided by contractor).

NOTE: 1 1/2 (38) or 2 (51) NPT inlet available. Add suffix -N

NOTE: Dimensions shown in parentheses are in millimeters.

The water closet gasket regularly furnished is made of molded neoprene and designed to fit water closet outlet dimensions and configurations shown in ANSI Standard A112.19.2M-1995, Figure 13B. If gasket is not found to be compatible to fixture due to nonconformance of said fixture to ANSI A112.19.2M, then fixture manufacturer shall be consulted for a suitable gasket recommendation. Jay R. Smith assumes no liability for connections to fixtures which do not conform to these standards.

- Fig. 0240L . . . CAULK Left Hand
- Fig. 0240R . . . CAULK Right Hand
- Fig. 0240D . . . CAULK Double
- Fig. 0270L . . . CAULK L.H. Long Barrel
- Fig. 0270R . . . CAULK R.H. Long Barrel
- Fig. 0270D . . . CAULK Double Long Barrel

© dimension = 4" (100) (regularly furnished) consisting of nipple and Adjus-to-Wall coupling permitting adjustment from 3" (76) min. to 4" (100) max.

A x B Size	C	D		E	F
		MIN	MAX		
4 x 4 (100) x (100)	9 (230)	1 1/2 (38)	4 1/4 (110)	10 (255)	3 (76)
5 x 4 (125) x (100)	11 1/2 (290)	1 1/2 (38)	4 1/4 (110)	11 1/2 (290)	3 1/2 (89)
5 x 5 (125) x (125)	11 1/2 (290)	1 1/2 (38)	4 1/4 (110)	11 1/2 (290)	3 1/2 (89)
6 x 4 (150) x (100)	11 1/2 (290)	1 1/2 (38)	4 1/4 (110)	11 1/2 (290)	4 (100)
6 x 5 (150) x (125)	11 1/2 (290)	1 1/2 (38)	4 1/4 (110)	11 1/2 (290)	4 (100)

Conforms with the requirements of ASME A112.6.1M up to a 500 lbs (227kg) static load rating.

DRAWING NUMBER S0240
 SIZE A
 SCALE: NONE
 DATE: 2-28-86
 APPROVED BY: JD
 CHECKED BY: CR
 DRAWN BY: CM
 0240,0270
 FIGURE NUMBER

WE CAN ASSUME NO RESPONSIBILITY FOR USE OF SUPERSEDED OR VOID DATA
 DIMENSIONS ARE SUBJECT TO MANUFACTURERS TOLERANCE AND CHANGE WITHOUT NOTICE

REV.	DATE	DESCRIPTION	BY	CKD. BY	WEIGHT POUNDS	VOLUME CUBIC FEET	FIGURE NUMBER
L	12-7-22	Added Note	KK	CL			0240,0270
K	10/09/99	Deleted Note	JJ	BS			
J	7-1-98	Submittal Update	ASL	BS			
H	1-23-98	Chg'd Callout	EMB	BS			

C
 DRAWING NUMBER S0200BS
 SIZE A
 SCALE: NONE
 DATE: 2-28-86
 APPROVED BY: JD
 CHECKED BY: CR
 DRAWN BY: VGD
 0200/0300 Series Back Sheet
 FIGURE NUMBER

SMITH® JAY R. SMITH MFG. CO.®
 MEMBER OF MORRIS GROUP INTERNATIONAL
 POST OFFICE BOX 3237
 MONTGOMERY, ALABAMA 36109-0237 (USA)
 TEL: 334-277-8520 FAX: 334-272-7396 www.jrsmith.com





MEMBER OF:

LOCATION

MODIFICATIONS & VARIATIONS

⊙ DIMENSION - ADJUS-TO-WALL TYPE OUTLET CONNECTION

The Smith Adjus-to-Wall outlet connection provides adjustment at the face of the wall at the time the fixture is set; thus, compensating for wall construction variations. The ⊙ dimension is measured from the front of the face plate to the finished wall. To properly determine the length of nipple required, deduct 1" (25) from the ⊙ dimension. When the ⊙ dimension exceeds 7" (180), the -M40 Wide Pipe Chase Support is recommended. The Adjus-to-Wall coupling will provide 1/2" (13) horizontal adjustment in either direction with the coupling extended 5/16" (8) past face of the finished wall.

⊙ dimension = 4" (100) (regularly furnished) consisting of nipple and adjus-to-wall coupling permitting adjustment from 3" (76) min. to 4" (100) max.

*ABS (Regularly Furnished) other length PVC.

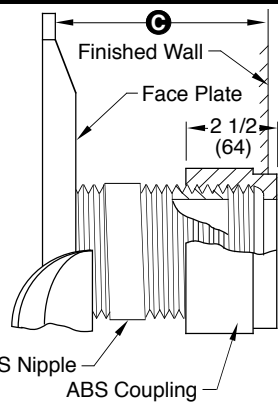

NIPPLE LENGTHS AVAILABLE

LENGTH	MIN	⊙	MAX
2 1/2 (64)	2 1/4 (57)	3 1/4 (83)	
*3 1/4 (83)	3 (76)	4 (100)	
*8 1/4 (210)	8 (205)	9 (230)	
10 (255)	9 3/4 (250)	10 3/4 (275)	
12 (305)	11 3/4 (300)	12 3/4 (325)	
15 (380)	14 3/4 (376)	15 3/4 (400)	
18 (455)	17 3/4 (450)	18 3/4 (475)	

NOTE: When nipple lengths between 3 1/4" (83) and 8 1/4" (210) are specified, the 8 1/4" (210) nipple will be supplied. Nipple must be cut to specified length by others.

RECOMMENDED SETTING OF CLOSET OUTLET CONNECTION AND FIXTURE STUDS

Manufacturers have slight differences in the depth of the closet horn and flange thickness of their closets. Usually the fixture support closet connection should extend 5/16" (8) beyond face of finished wall (Dimension "R") and the fixture studs 2 1/4" (57) (Dimension "X"). For exact dimensions please use the formulas below.

DETAIL A Formula for "R" is: $S + 1/16" (2) - D = R$.

S = Depth of closet horn
 1/16" (2) = Distance closet is to set away from finished wall.
 D = 1/2" (13) for felt gasket and 3/8" (10) for neoprene gasket.
 R = Distance coupling should extend beyond finished wall.
 NOTE: When the fixture is installed, closet gasket must be compressed sufficiently to assure a gas and water-tight seal.

DETAIL B Formula for "X" is: $Y + 1/16" (2) + 9/16" (14) = X$.

Y = Thickness of closet wall flange.
 1/16" (2) = Distance closet is to set away from finished wall.
 X = Distance supporting stud should extend beyond finished wall.
 NOTE: Bearing nuts and washers must be set to take full loading from the fixture allowing 1/16" (2) clearance between fixture and wall.

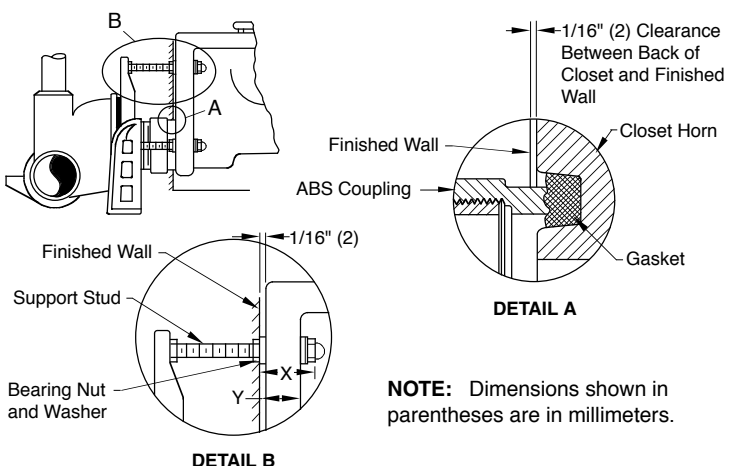

NOTE: Dimensions shown in parentheses are in millimeters.

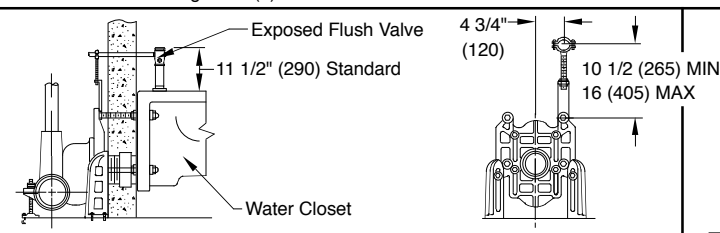

Provides support and alignment for the supply pipe to an exposed flush valve; must be specified for either 1" (25) copper tube or 1" (25) iron pipe.

SUFFIX -M12 EXPOSED FLUSH VALVE SUPPLY SUPPORT

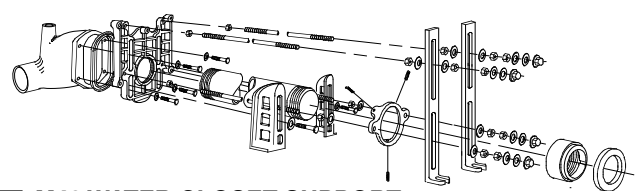

-M40 WATER CLOSET SUPPORT FOR WIDE PIPE CHASE (USE WHEN ⊙ DIMENSION EXCEEDS 7" (180))

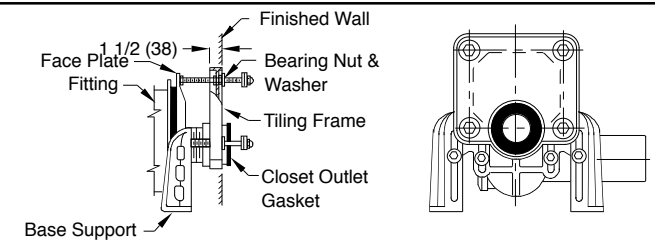

SUFFIX -M13 TILING FRAME - POLYSTYRENE

CONCEALED FLUSH VALVES

A concealed flush valve when used with a blowout water closet support will not clear the face plate. Therefore 4 1/2" (115) to 6 1/2" (165) is required from back of wall to face plate to permit the installation of the concealed flush valve piping.

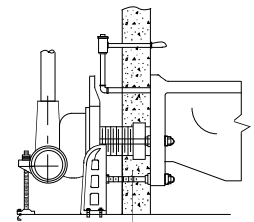

REV.	DATE	DESCRIPTION	BY	CKD. BY	WEIGHT POUNDS	VOLUME CUBIC FEET	FIGURE NUMBER
C	12-10-03	Revised Notes	RN	CL			0200/0300 Series Back Sheet
B	6-1-95	Added Millimeters	EMB	BS			
A	7-1-93	Submittal Update	EMB	BS			