

**Florestone
Model 20WM
Utility Sink**

20" x 24" x 13½"

20WM-1 (1/Box):

Weight:

30 lbs.

20WM-3 (3/Box):

85 lbs.

Capacity

19 gallons

**Architect's
Specifications**

Furnish and install Utility Sink Model 20WM as manufactured by Florestone Products Co. Wall mounted sink to include wall mounting bracket and hardware to attach unit to wall, and drain plugs with hardware.

Color will be white and will be resistant to fading and abrasion.

Unit to have 1½" drain opening.

Optional and Accessories

20WM Accessory Kit

Standards

I.A.P.M.O. Listed File 2647
ANSI-Z-124.6-97



CSA Test • Warnock Hersey Listed:
CAN/CSA-B45.0 - CAN/CSA-B45.5

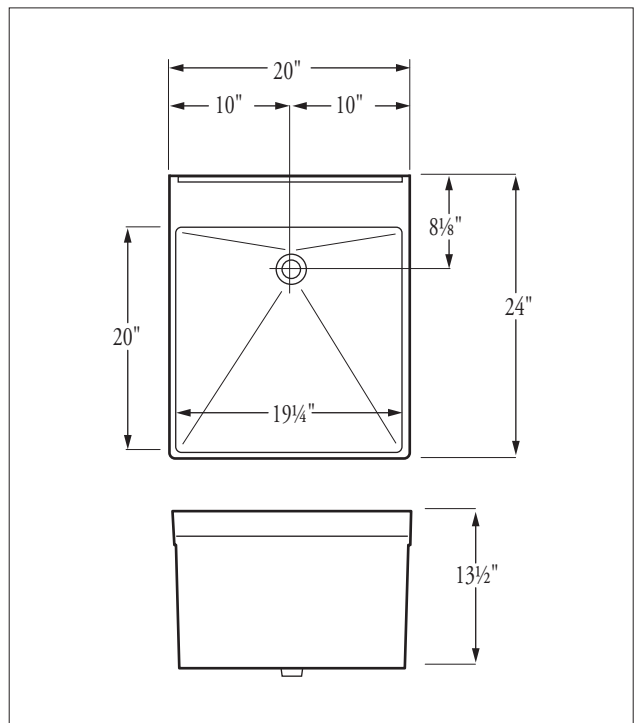

Inside Tray Dimensions: 20" x 19¼"



FLORESTONE PRODUCTS CO., INC.

2851 Falcon Drive • Madera, CA 93637

T. 559.661.4171 • T. 800.446.8827

F. 559.661.2070 • florestone.com