

## Residential Ultra Low NOx High Input Gas Water Heater

### The Atmospheric Vent High Input Models Feature:

- **Bradford White ICON System®\***—Intelligent gas control with proven millivolt powered technology and built-in piezo igniter. A standard, off-the-shelf thermopile converts heat energy from the pilot flame into electrical energy to operate the gas valve and microprocessor. No need for external electricity.
  - **Enhanced Performance**—Proprietary algorithms provide enhanced First Hour Rating and tighter temperature differential.
  - **Advanced Temperature Control System**—Microprocessor controls burner operation for consistent and accurate water temperature levels up to 160°F (71°C).
  - **Intelligent Diagnostics**—Exclusive multicolor LED light indicates operation status/ service required.
- **Defender Combustion Chamber**—Incorporates the Advanced ScreenLok® Technology Flame Arrestor and large split-door design to prevent ignition of flammable vapors outside the water heater (URG250H6N only).
- **Ultra Low NOx Burner with Primary and Secondary Air Distribution Devices**—Ensures proper air to gas ratio for reduction of NOx generated by the combustion process.
- **Digital Thermal Sensor and Resettable Thermal Switch**—Coordinates with self diagnostic control to prevent water heater operation when needed (URG250H6N only).
- **Maintenance-Free**—No regular cleaning of air inlet openings or flame arrestor is required under normal conditions (URG250H6N only).
- **Sight Window**—Offers a view into the combustion chamber to observe the operation of the pilot and burner.
- **Factory-Installed Hydrojet® Total Performance System**—Sediment reducing device that also increases first hour rating of hot water while minimizing temperature build-up in tank.
- **Vitraglas® Lining**—An exclusively engineered enamel formula that provides superior tank protection from the highly corrosive effects of hot water. This formula (Vitraglas®) is fused to the steel surface by firing at a temperature of over 1600°F (871°C).
- **Side Connections**—3/4" (19mm) NPT tapings allow an easy connection for space heating applications.
- **Insulation System**—Non-CFC foam covers the sides and top of the tank, reducing heat loss. This results in less energy consumption, improved efficiencies, and jacket rigidity.
- **Pedestal Base**—Rugged and durable base allows easy transport and positioning while providing corrosion-resistant contact with floor (URG250H6N / URG275H6N only).
- **Water Connections**—Factory-installed true dielectric fittings extend water heater life and simplify water line connections.
- **Factory-Installed Heat Traps**—Design incorporates a flexible disk that reduces heat loss in piping and eliminates the potential for noise generation.
- **Protective Magnesium Anode Rod**—Provides added protection against corrosion for long-term, trouble-free service.
- **4" (107mm) "Snap Lock" Draft Diverter.**
- **T&P Relief Valve**—Installed.
- **Low Restrictive Brass Drain Valve**—Durable tamper proof design.
- **Design Certified by CSA International (formerly AGA/CGA).**
- **URG250H6N complies with the latest Ultra Low NOx requirement (10 ng/J NOx limit)**  
URG275H6N / URG2100H6N comply with (14 ng/J NOx limit).



Photo is of  
URG250H6N

### FEATURING:



### 6 or 10-Year Limited Tank Warranties / 6 or 10-Year Limited Warranty on Component Parts.

For more information on warranty, please visit [www.bradfordwhite.com](http://www.bradfordwhite.com)

For products installed in USA, Canada, and Puerto Rico. Some states do not allow limitations on warranties.

See complete copy of the warranty included with the heater.

# Residential Ultra Low NOx High Input Gas Water Heater

## Ultra Low NOx Models

NATURAL GAS

Meet or exceed ASHRAE 90.1b (current standard) C.E.C. Listed  
Recovery efficiency ranging up to 79%

Model Number	Nominal Gal. Capacity		DOE Rated Storage Volume (Gal.)	Input BTU/Hr.	First Hour Rating (Gal.)	Uniform Energy Factor	Recovery at 90°F Rise*		Model Number	Nominal Liter Capacity	DOE Rated Storage Volume (Liters)	Input kW	First Hour Rating (Liters)	Uniform Energy Factor	Recovery at 50°C Rise*	
	U.S. Gal.	Imp. Gal.					U.S. GPH	Imp. GPH							Liters/Hour	
URG250H6N	48	40	46	55,000	110	0.64	59	49	URG250H6N	182	174	16.1	417	0.64	223	
URG275H6N	75	62	72	76,000	135	0.59	82	68	URG275H6N	284	273	22.3	512	0.59	310	
URG2100H6N	100	83	95	80,000	157	0.57	85	71	URG2100H6N	379	360	23.4	595	0.57	322	

Model Number	A Floor to Flue Conn. in.	B Jacket Dia. in.	C Vent Size in.	D Floor to T&P Conn. in.	E Floor to Gas Conn. in.	F Floor to Top of Heater in.	G Floor to Water Conn. in.	H Depth in.	J C/L of Water Conn. in.	K Floor to Space Heating Inlet in.	L Floor to Space Heating Outlet in.	M Water Conn. NPT in.	R Space Heating Conn. Size in.	S Gas Conn. Size in.	Approx. Shipping Weight lbs.
URG250H6N	60 <sup>5</sup> / <sub>8</sub>	22	4	49 <sup>7</sup> / <sub>8</sub>	11 <sup>7</sup> / <sub>16</sub>	56 <sup>3</sup> / <sub>4</sub>	58 <sup>1</sup> / <sub>16</sub>	25 <sup>3</sup> / <sub>8</sub>	11	13 <sup>3</sup> / <sub>8</sub>	49 <sup>7</sup> / <sub>8</sub>	3/4	3/4	1/2	194
URG275H6N	64 <sup>1</sup> / <sub>4</sub>	26	4	53 <sup>3</sup> / <sub>8</sub>	15 <sup>1</sup> / <sub>8</sub>	60 <sup>3</sup> / <sub>16</sub>	61 <sup>3</sup> / <sub>4</sub>	29 <sup>3</sup> / <sub>8</sub>	11	16 <sup>11</sup> / <sub>16</sub>	53 <sup>3</sup> / <sub>8</sub>	1	3/4	1/2	286
URG2100H6N	69 <sup>3</sup> / <sub>8</sub>	28 <sup>1</sup> / <sub>4</sub>	4	60 <sup>3</sup> / <sub>8</sub>	16 <sup>1</sup> / <sub>2</sub>	66 <sup>1</sup> / <sub>2</sub>	68 <sup>5</sup> / <sub>8</sub>	31 <sup>3</sup> / <sub>4</sub>	16	18 <sup>3</sup> / <sub>4</sub>	51 <sup>11</sup> / <sub>16</sub>	1 <sup>1</sup> / <sub>4</sub>	3/4	1/2	416

Model Number	A Floor to Flue Conn. mm.	B Jacket Dia. mm.	C Vent Size mm.	D Floor to T&P Conn. mm.	E Floor to Gas Conn. mm.	F Floor to Top of Heater mm.	G Floor to Water Conn. mm.	H Depth mm.	J C/L of Water Conn. mm.	K Floor to Space Heating Inlet mm.	L Floor to Space Heating Outlet mm.	M Water Conn. NPT mm.	R Space Heating Conn. Size mm.	S Gas Conn. Size mm.	Approx. Shipping Weight kg.
URG250H6N	1540	559	102	1267	291	1441	1475	645	279	340	1267	19	19	13	88
URG275H6N	1638	660	102	1356	384	1532	1568	746	279	424	1356	25	19	13	130
URG2100H6N	1762	718	102	1534	419	1689	1743	806	406	476	1313	32	19	13	189

Available in Natural Gas only.

For 10 year models, change suffix from "6" to "10".

\* Based on manufacturer's rated recovery efficiency.

Uniform Energy Factor and First Hour Rating is based on the latest AHRI directory listings.

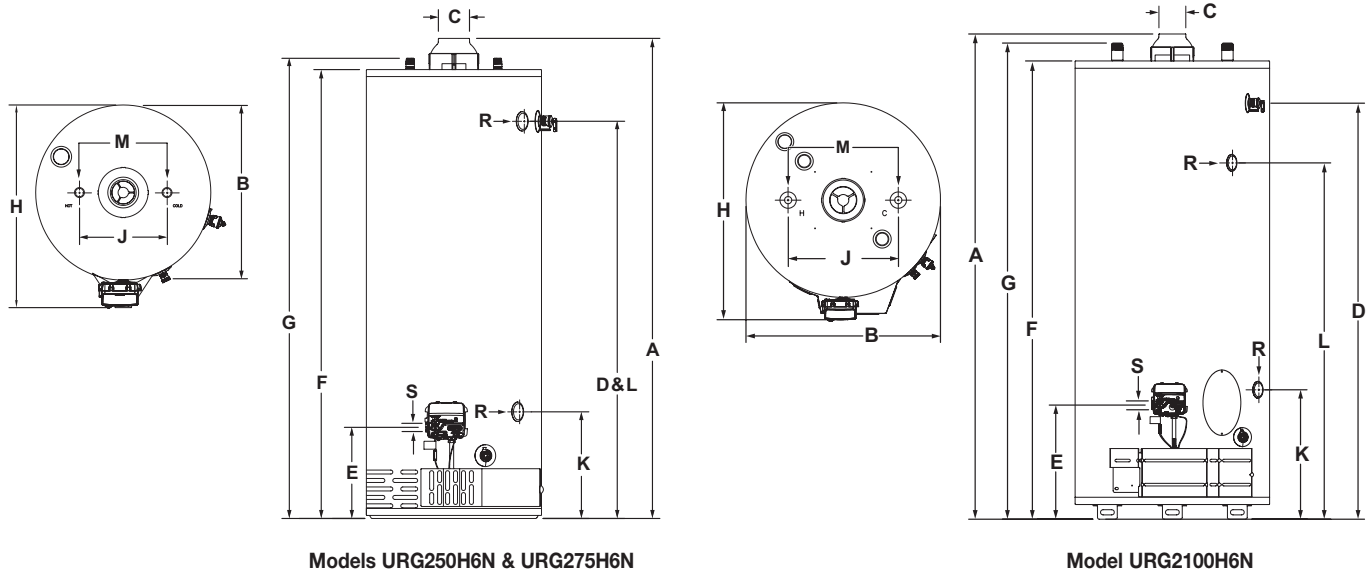

### General:

Meets NAECA or EPACK Requirements, as applicable.

All gas water heaters are certified at 300 PSI test pressure (2068 kPa) and 150 PSI working pressure (1034 kPa). All Gas Connections are 1/2" (13mm).

All models design-certified by CSA International (formerly AGA/CGA), to meet ANSI standard Z21.10.3 (Z21.10.1 for 48-gallon) and peak performance rated.

**Dimensions and specifications subject to change without notice in accordance with our policy of continuous product improvement.**

**Suitable for Water (Potable) Heating and Space Heating.** Toxic chemicals, such as those used for boiler treatment, shall NEVER be introduced into this system. This unit may NEVER be connected to any existing heating system or component(s) previously used with a non-potable water heating appliance.

— BRADFORD WHITE IS —



For field service, contact your professional installer or local Bradford White sales representative.

Sales 800-523-2931 ■ Fax 215-641-1612

Technical Support 800-334-3393 ■ Email [techserv@bradfordwhite.com](mailto:techserv@bradfordwhite.com)

Warranty 800-531-2111 ■ Email [warranty@bradfordwhite.com](mailto:warranty@bradfordwhite.com)

International: Telephone 1-215-641-9400 ■ Email [international@bradfordwhite.com](mailto:international@bradfordwhite.com) / [www.bradfordwhite.com](http://www.bradfordwhite.com)

**Built to be the Best™**